

## HF box power packs

dc box power packs for mobile applications

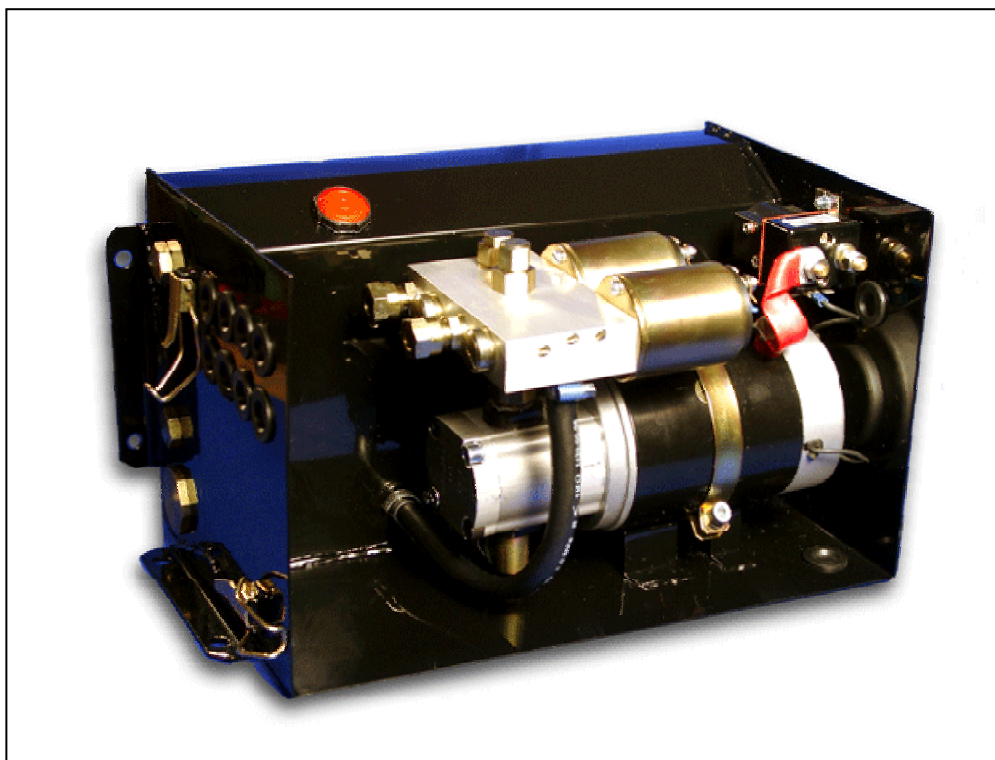

### HF box power pack series

Hydraulfunktion has more than 20 year successfully manufactured and constantly improved box type dc power packs.

HF box power packs is a modular series which covers the most typical applications in the vehicle building and material handling industry.



What does HYDRAULFUNKTION stand for?

HYDRAULFUNKTION is dedicated to customer satisfaction. Our goal is to offer our customers

- good service
- good quality products
- a fair price even at low quantities
- the best technical support

HYDRAULFUNKTION is specialized in the production of small and medium size series. We want to give small companies in the vehicle building industry access to products, services and PRICES that are common in the high volume OEM markets.

We know, that small manufacturers in the vehicle building are doing a wonderful job; innovative and flexible. We want to support this type of company.

If you have any ideas, questions or problems, please don't hesitate to contact HYDRAULFUNKTION AB.

HYDRAULFUNKTION AB  
Kungsgatan 67  
S-341 32 Ljungby  
hf@hydraulfunktion.se  
Tel.: +46(0)372-15840  
Fax.: +46(0)372-15843

## Hydraulic Power Units

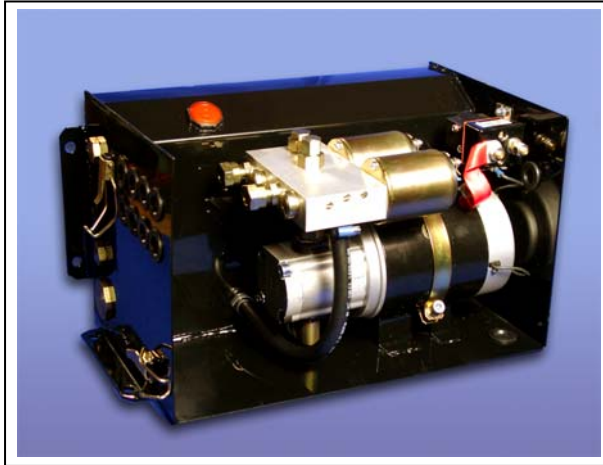

Hydraulfunktion – or just *HF*!  
„Classic“ and robust is our way of  
constructing DC power units

### **Solutions and Concepts for reliable Mobile Hydraulics**

*Hydraulfunktion* AB is a Sweden based company manufacturing and dealing in a wide range of hydraulic units. Our hydraulic power packs are used by a increasing number of well known manufacturers in vehicle construction and machine engineering. By the combination of a variety of hydraulic pumps, DC-motors and valve-systems we cover the typical range of applications and functions.

Today *Hydraulfunktion* AB has customers in no less then 22 different countries across the world and we strongly believe that our competitive prices, the quality of our products and the level of service offered will enable us to expand our presence in the market. With a capacity of 20.000 units a year our standard time of delivery is 1-2 weeks.

Convince yourself of the robustness, reliability and high quality standard of our hydraulic power units.

#### **Example applications:**

- tailgates
- steering axle
- loader cranes
- dumpers
- lift- and crane constructions
- emergency hydraulic
- special constructions

**HF**  
power packs  
for mobile hydraulics

# Hydraulic Power Units



## HF power Packs for mobile hydraulics

### Example applications:

- tailgates
- steering axle
- loader cranes
- dumpers
- lift- and crane constructions
- emergency hydraulic
- special constructions

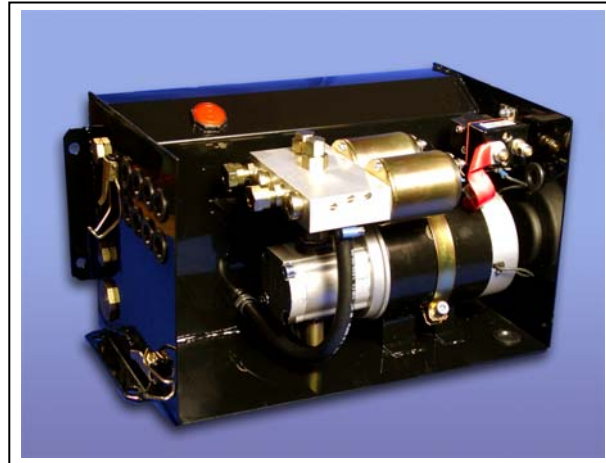

### Flexible and robust solutions

HF power units consist of a dc motor, gear pump and valve system mounted in a robust cabinet. By the combination of dc motors rated from 0,8kW up to 4,5kW, various size gear pumps and flexible valve solutions, HF power units cover a wide range of applications.

- single acting functions
- double acting functions
- combined single and double acting functions

### overview on valve combination

functions	Valve system	3/2 directional valve
1 x single acting	HF21 (Art.-Nr.: 4121)	—
2 x single acting*		1 x HF 36 (Art.-Nr.: 4136)
1x double acting	HF127 (Art.-Nr.: 4127)	—
1 x single acting 1 x double acting		1 x HF 36 (Art.-Nr.: 4136)
2 x double acting		2 x HF 36 (Art.-Nr.: 4136)
2 x single acting*	HF199 (Art.-Nr.: 4199)	—
external valves	-	-
external valves	HF100	-

\* Both signed valve system are used for several single acting function. Directional valve HF99 is a more compact construction. Use directional valves HF21 and HF36 in combination in order to upgrade existing power units.

# Hydraulic Power Packs



**Main components:**

- DC Motor
- Pump
- Valve system
- cabinet / tank

For configuration of power units, please use order code below.

*Hydraulfunktion* also builds customized power units and valve systems.

**Order code**

example:

6012-24-3,2-D

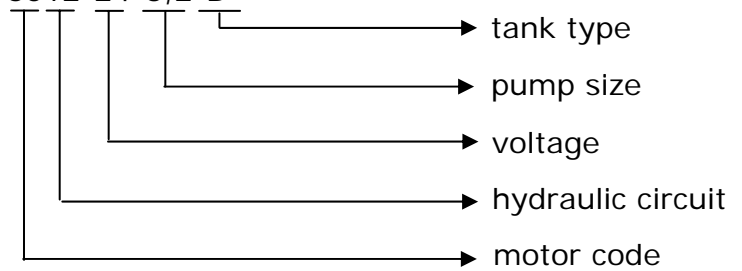

dc motor options:

Code	Motor	Art.-Nr.: Motor
50	0,8kW	0812 / 0824
60	2kW	1024 / 1012
80	2kW with fan	1312 / 1324
70	3kW	1112 / 1124
71	3kW with fan	1612 / 1624

hydraulic circuits:

Code	funktions	base valve	3/2 change over va
10	1 x single acting	HF121	
11	2 x single acting	HF121	1 x HF136
12	1 x double acting	HF127	
13	1 x double acting + 1 x single acting	HF127	1 x HF136
13	3 x single acting	HF127	1 x HF136
14	2 x double acting	HF127	2 x HF136
14	2 x single acting + 1 double acting	HF127	2 x HF136
18	2 x single acting	HF199	
20	relief valve + check valve	HF100	
99	usage with external valves	-	-

gear pump options:

Code	Pump	Art.-Nr.:
0,8	0,8 ccm P4	2108
1,7	1,7 ccm P9	2117
2,6	2,6 ccm P13	2126
3,2	3,2 ccm P17	2132
4,3	4,3 ccm P22	2143
5	5,0 ccm	2150

tank options:

Code	Tank (Art.-Nr.:	Tank volume (approx.)
A	5001	10,0
B	5002	9,6
C	5003	6,2
D	5004	9,8
E	5005	4,5
F	5006	16,0
G	5007	16,0

## HF 6099 / 7099

dc hydraulic power packs  
for usage with external valves



Power pack for usage  
with external valves

Possible configurations

- dc motor: 2kW, 2,5kW or 3kW  
(12V, 24V and 48V)
- pumps: 0,85ccm – 5,0ccm
- tanks: available up to 16 Liter

components:

- 1 pc dc motor
- 1 pc hydraulic gear pump  
(pressure balanced)
- 1 pc cabinet / tank
- 1 pc starter switch
- mounting material (incl.):
  - 1 pc suction elbow
  - 1 pc suction pipe
  - 2 pc bolts M8x90
  - 1 pc motor strap
  - 1 pc connection cable

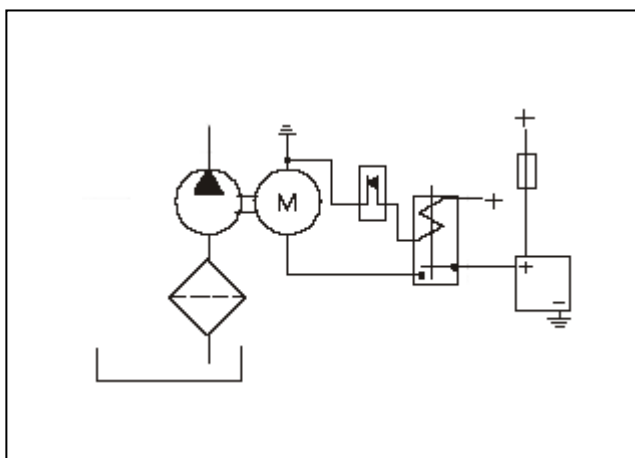

## HF 6010 / 7010

DC hydraulic power unit for single acting functions



hydraulic power unit for single acting functions

e.g. for light tippers

Available options

- motor: 2kW or 3kW
- pumps: 0,85ccm – 5,0ccm
- lowering brake valve  
(for load independent lowering speed)
- tank size: up to 16 liters

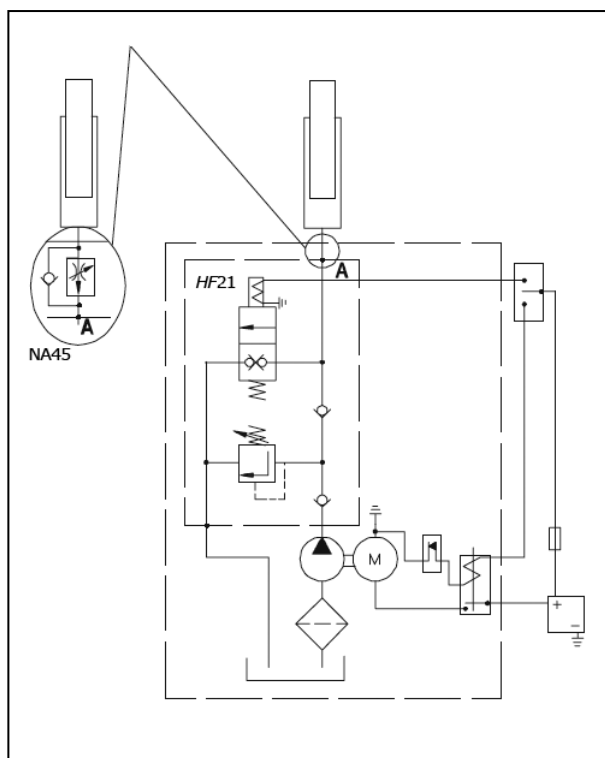

## HF 6011 / 7011

DC hydraulic power unit for two single acting functions



hydraulic power unit for two single acting functions

e.g. for tail gate lifts

Available options

- motor: 2kW or 3kW
- pumps: 0,85ccm – 5,0ccm
- lowering brake valve  
(for load independent lowering speed)
- tank size: up to 16 liters

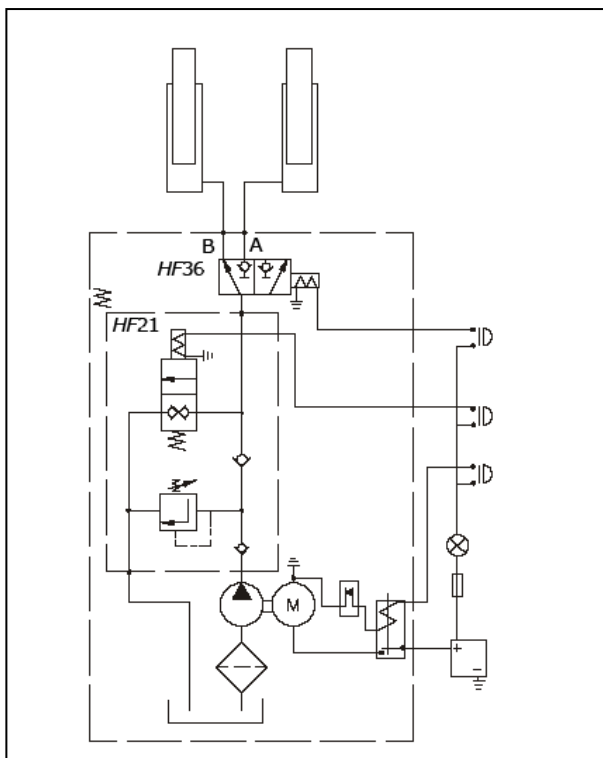

## HF 6012 / 7012

DC hydraulic power unit for double acting functions

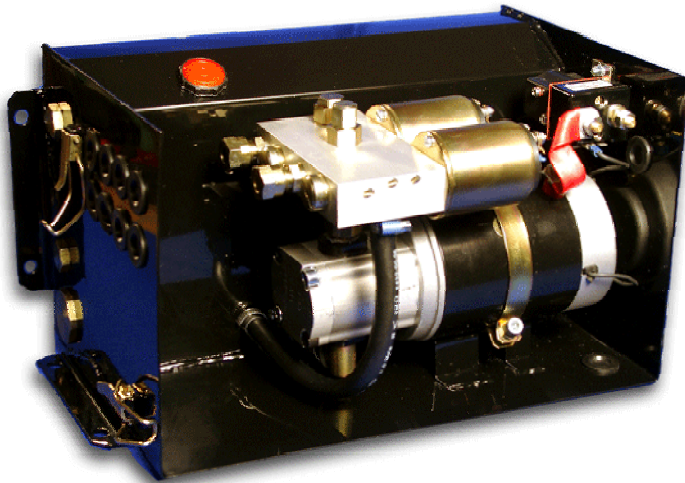

hydraulic power unit for double acting functions

Available options

- motor: 2kW or 3kW
- pumps: 0,85ccm – 5,0ccm
- tank size: up to 16 liters

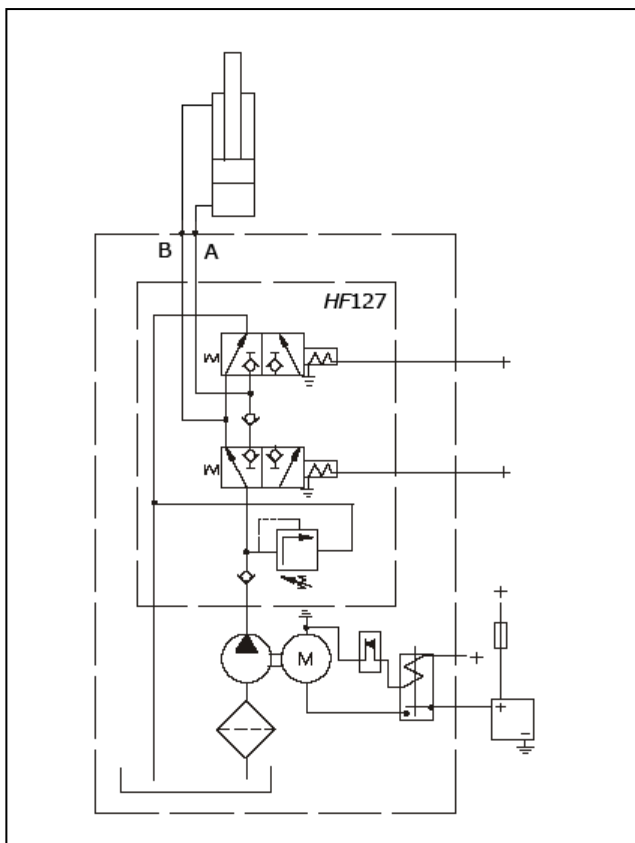

## HF 6012TP / 7012TP

DC hydraulic power unit for double acting functions

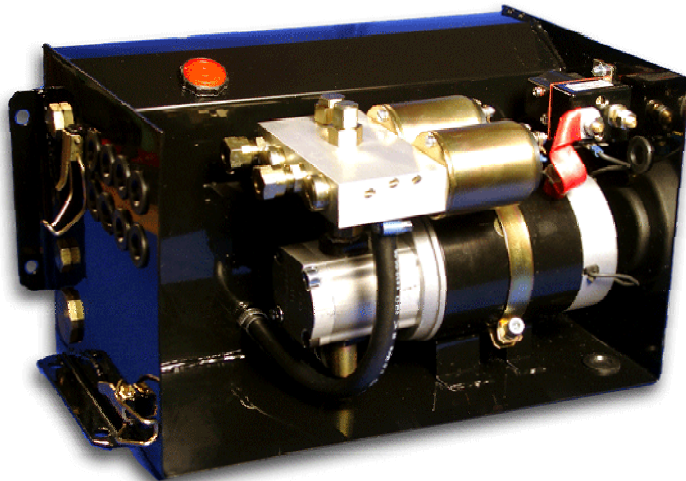

hydraulic power unit for double acting functions  
incl. pressure switch  
e.g. for bogie lifts

Available options

- motor: 2kW or 3kW
- pumps: 0,85ccm – 5,0ccm
- tank size: up to 40 liters

Pressure switch:

Power units "TP" are with adjustable pressure switch HF3040.

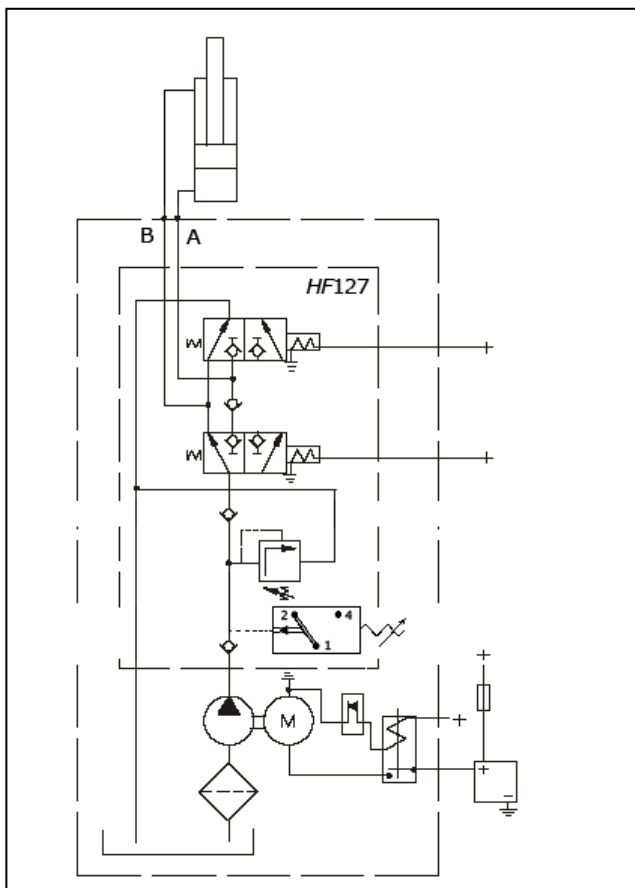

## HF 3040

Adjustable piston pressure switches with push-on terminals

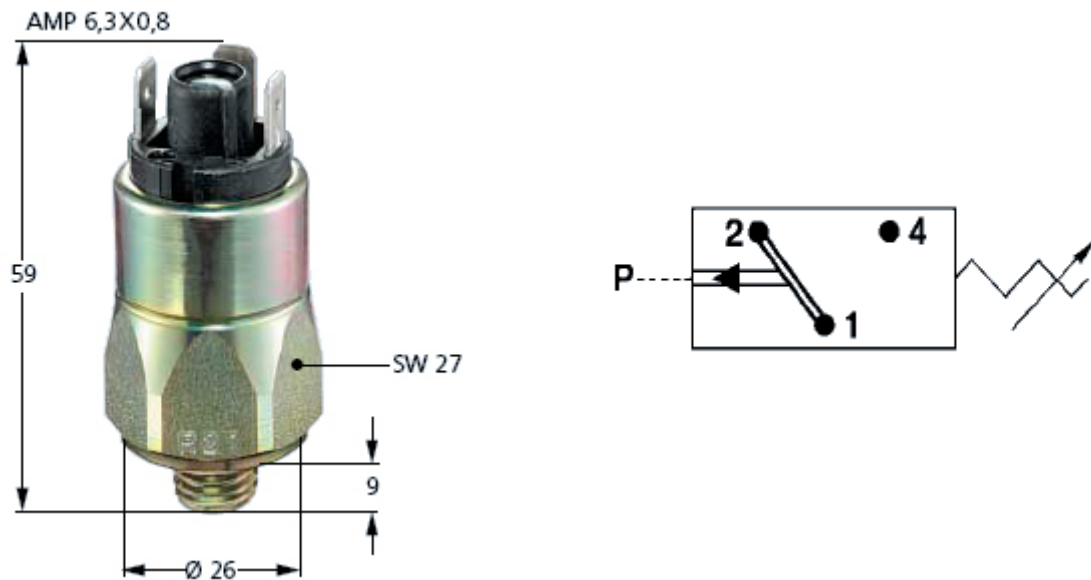

### Specification:

- adjustment range 50-200 bar
- piston pressure switches with push-on terminals
- changeover switch
- silver contacts
- overpressure safe to 600bar  
(static pressure; dynamic pressure should be 30-50% lower)
- tolerance 5 bar (at room temperature)
- G1/4" threads

# HF 6013 / 7013

DC hydraulic power unit for double acting functions

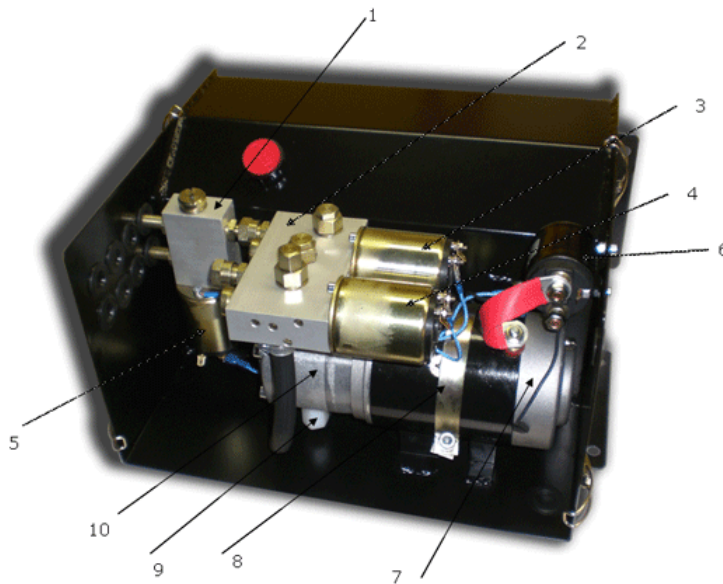

hydraulic power unit for mixed double and single acting functions  
e.g. for tail gate lifts

- Available options
- motor: 2kW or 3kW
  - pumps: 0,85ccm – 5,0ccm
  - tank size: up to 40 liters

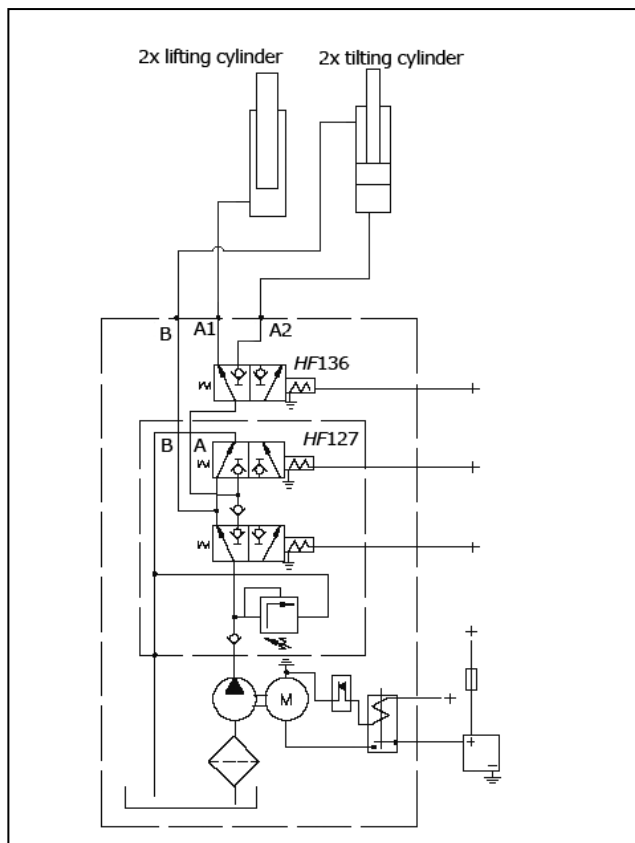

## HF 6014 / 7014

DC hydraulic power unit for 2 double acting functions

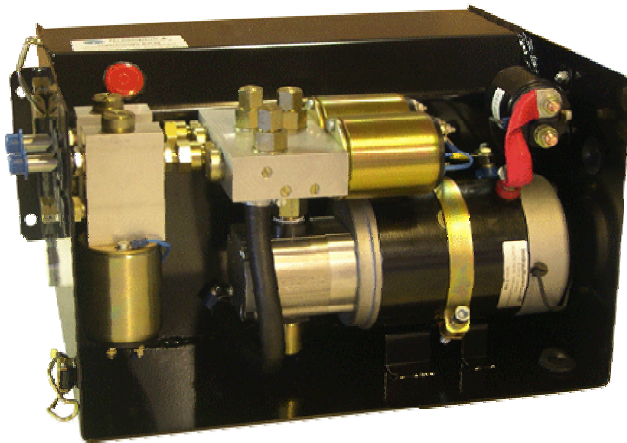

hydraulic power unit for double acting functions

e.g. for bogie lifts

Available options

- motor: 2kW or 3kW
- pumps: 0,85ccm – 5,0ccm
- tank size: up to 16 liters

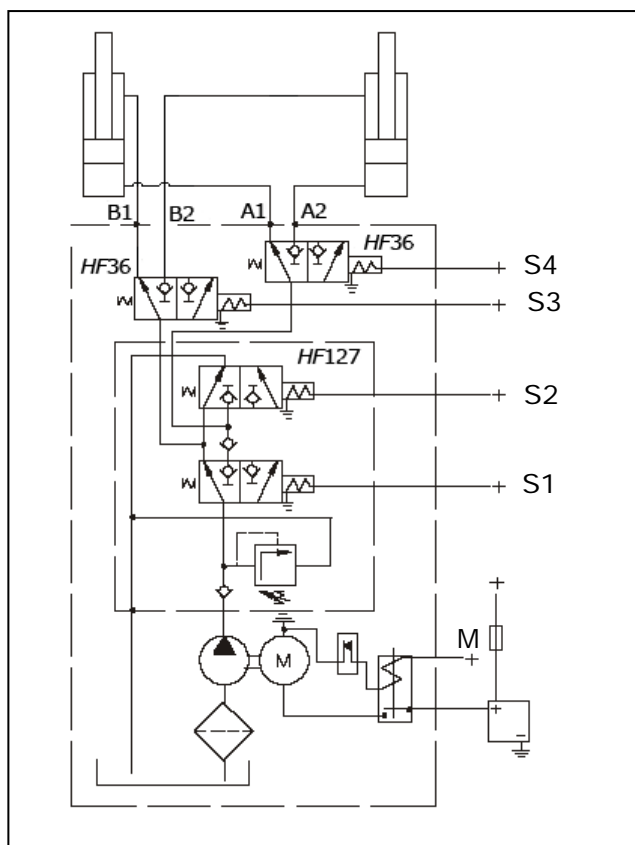

## HF 6018 / 7018

DC hydraulic power unit for two single acting functions

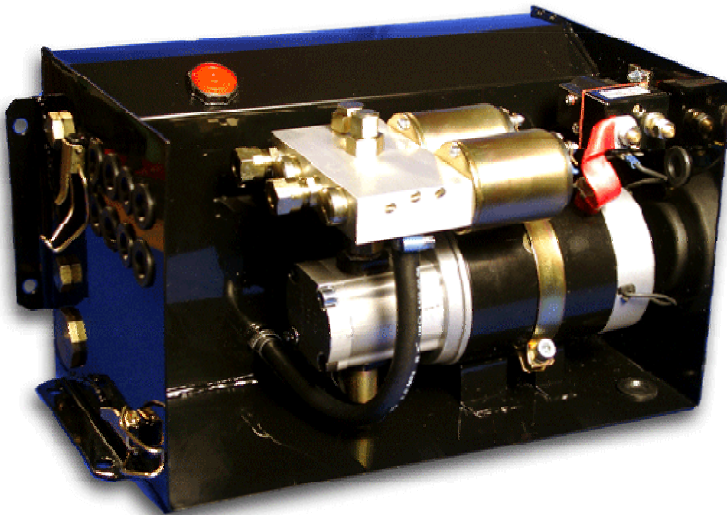

hydraulic power unit for two single acting functions

e.g. for tail gate lifts

Available options

- motor: 2kW or 3kW
- pumps: 0,85ccm – 5,0ccm
- lowering brake valve (for load independent lowering speed)
- tank size: up to 16 liters

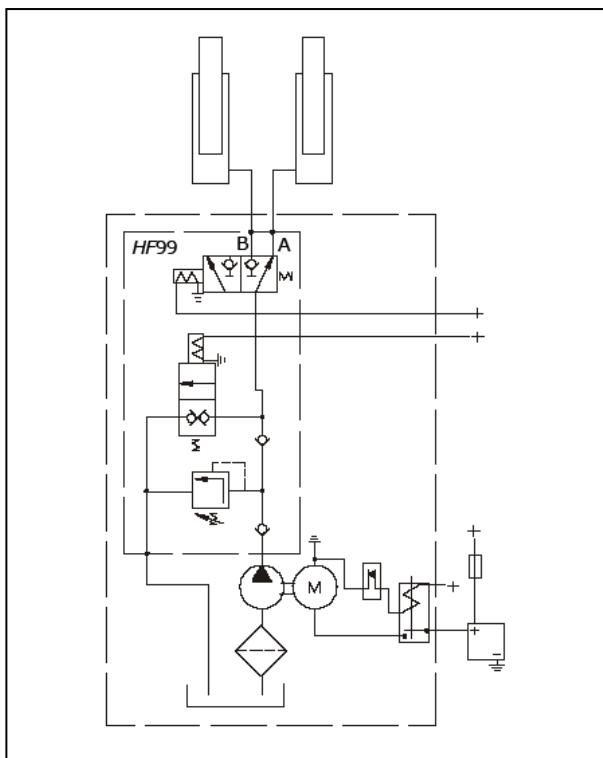



## Typical power packs

The following pages present a number of typical and popular power packs. We hope it can give you some ideas about how and where to use HF box power packs.

If you have any questions, please don't hesitate to contact HYDRAULFUNKTION AB, or one of our distributor.

HYDRAULFUNKTION AB  
Kungsgatan 67  
S-341 32 Ljungby  
[hf@hydraulfunktion.se](mailto:hf@hydraulfunktion.se)  
Tel.: +46(0)372-15840  
Fax.: +46(0)372-15843

## HF 7199

### DC hydraulic power unit for external valves

This hydraulic power unit (12V / 24V) is designed for the use with external directional valves. On small trucks where a PTO driven pumps are not available or not economic, this unit can be used as a alternative.

#### Advantages:

- economic pricing
- easy installation
- Truck engine don't have to be on while operating (environmentally friendly and low noise level)

hydraulic power unit for use with external directional valves  
e.g. for light loading cranes

#### specification

- motor: 3kW (24V) with fan
- pumps: 0,85ccm – 5,0ccm
- tanks: different types available  
see tank specification

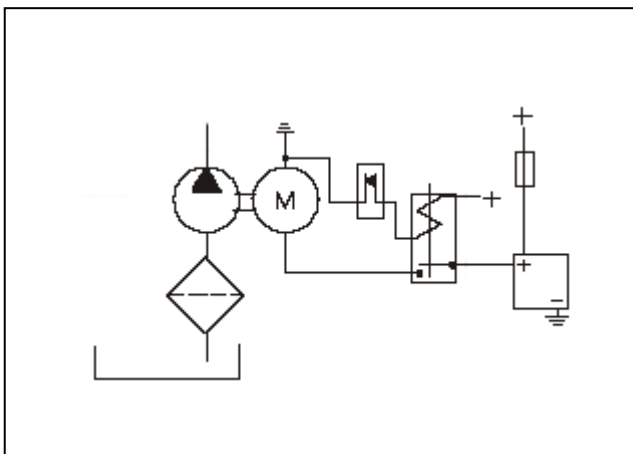

## HF 7120

### DC hydraulic power unit with relief valve HF100

This hydraulic power unit (12V / 24V) is designed for the use with external directional valves. On small trucks where a PTO driven pumps are not available or not economic, this unit can be used as a alternative.

#### Advantages:

- economic pricing
- easy installation
- Truck engine don't have to be on while operating (environmentally friendly and low noise level)

hydraulic power unit for use with external directional valves  
e.g. for light loading cranes

#### specification

- motor: 3kW (24V) with fan
- pumps: 0,85ccm – 5,0ccm
- valve: adjustable relief valve  
With check valve (HF100)
- tanks: different types available  
see tank specification

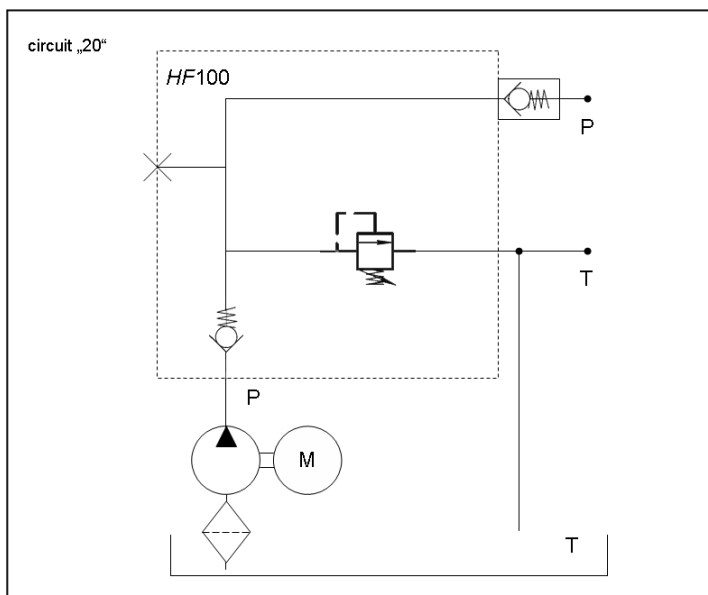

# HF 7120

DC hydraulic power unit with relief valve HF100

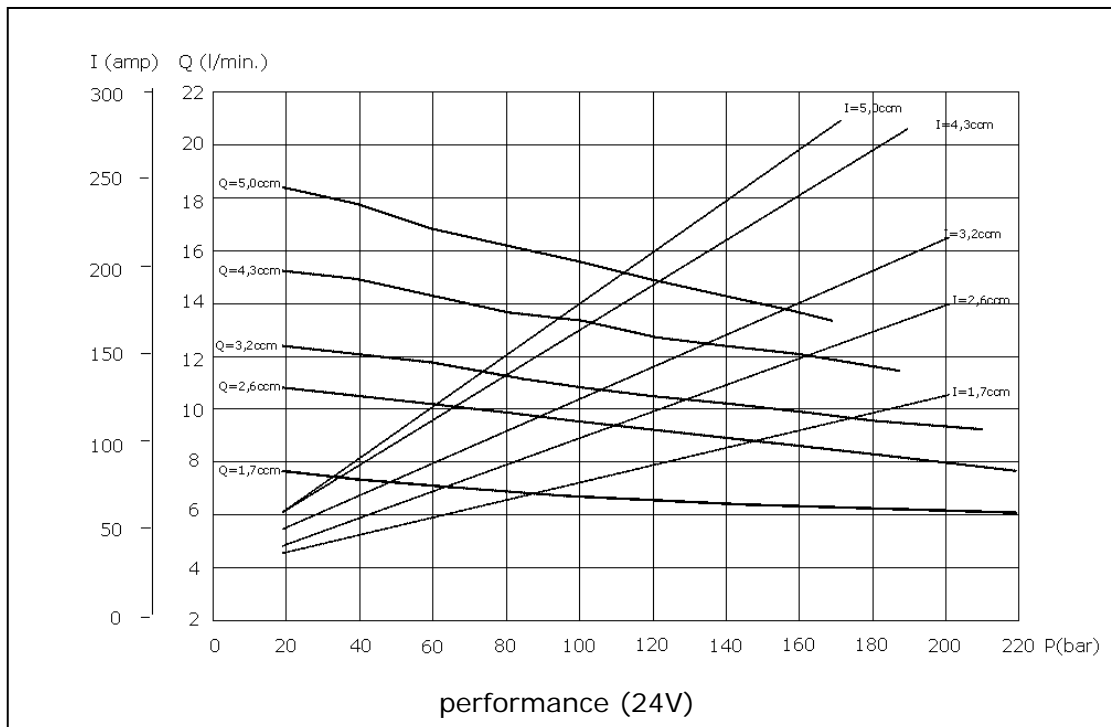

**Performance:**

dc motor:	3kW (24V)	art.-nr.: 1624
	3kW (12V)	art.-nr.: 1612
gear pumps:	1,7ccm	art.-nr.: 2117
	2,6ccm	art.-nr.: 2126
<b>Code "Vg"</b>	3,2ccm	art.-nr.: 2132
describes	4,3ccm	art.-nr.: 2143
Pump code	5,0ccm	art.-nr.: 2150

**Order code:**

Base code:	7120-24-Vg-T (24V)
	7120-12-Vg-T (12V)

pumps "Vg":	1,7ccm	art.-nr.: 2117
	2,6ccm	art.-nr.: 2126
	3,2ccm	art.-nr.: 2132
	4,3ccm	art.-nr.: 2143
	5,0ccm	art.-nr.: 2150

Tank code "T": see table

**available tanks:**

type:	art.-nr.:	width	depth	height	volume
"A"	5001	445	262	330	11,0 L
"B"	5002	445	311	240	11,2 L
"F"	5006	600	262	330	16,0 L
"G"	5007	445	400	240	16,0 L

3kW power packs cannot be assembled with tanks code "E, C and D"

## HF 6012-24-3,3-DTP

DC hydraulic power unit for bogie lift axle

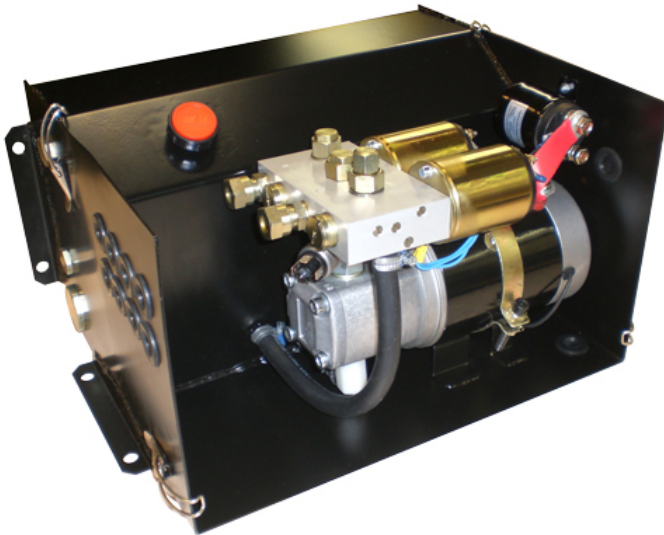

This hydraulic power pack is designed for electro-hydraulic rear axis bogie lifts.

### Replacement:

It can replace the units of the main manufacturers like Scania, Volvo and Sisu Trucks.

### Advantages:

- full 1 year guarantee
- fast fitting = reduced costs
- easy to fit (4 bolts)
- adaptable to existing hydraulic system
- reliable

**This power pack is designed as replacement for Scania, Volvo and Sisu Trucks.**

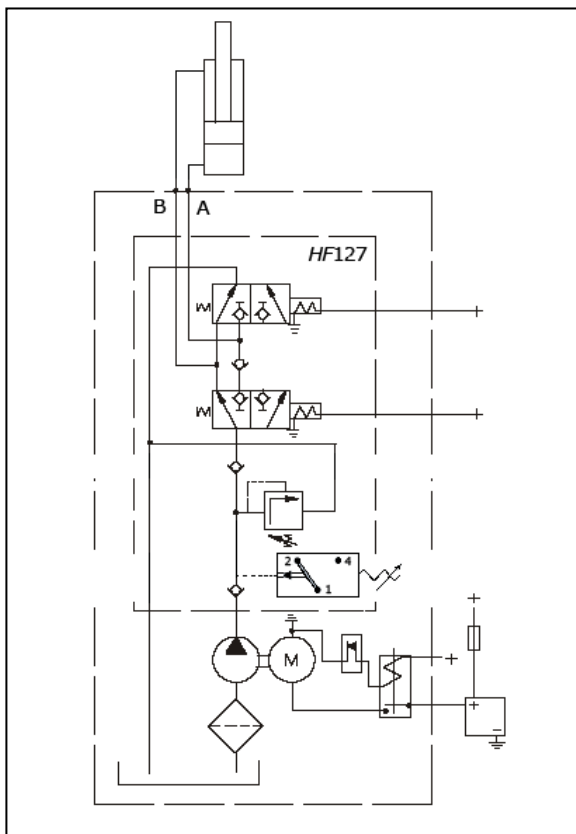

HF power pack type "6012-24"

hydraulic power unit for double acting functions.

incl. pressure switch

for bogie lifts

Pressure switch:

Power units "TP" are with adjustable pressure switch HF3040.

## HF power packs boxes tank / cabinets

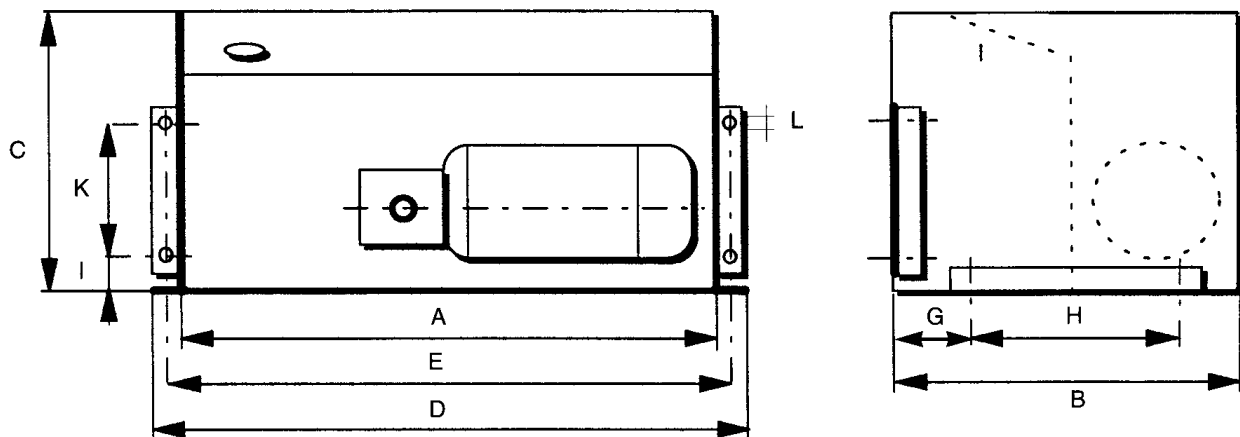

dimensions	type „A“	type „B“	type „C“	type „D“	type „E“	type „F“	type „G“
A	445	445	400	400	315	600	445
B	265	311	265	332	265	270	400
C	330	240	245	240	240	330	240
D	495	495	450	450	365	650	495
E	475	475	430	430	345	630	475
G	60	60	60	110	60	60	60
H	120	120	120	120	120	120	120
I	60	60	60	60	60	60	60
K	120	120	120	120	120	120	120
L	ø10,8	ø10,8	ø10,8	ø10,8	ø10,8	ø10,5	ø10,5
Oil volume	10,0 L	9,6 L	6,2 L	9,8 L	4,5 L	16 L	16 L
motors	all types	all types	2kW	2kW	2kW	all types	all types

The cabinets (boxes) are an integral component of the box power pack, they are a protection for the components and they include the oil tank.

The HF box power pack series includes 7 standard models of tank cabinets.



HYDRAULFUNKTION AB

Other HF products

HYDRAULFUNKTION is manufacturing dc hydraulic power pack and hydraulic components. This includes 3 main product groups

Dc box power packs

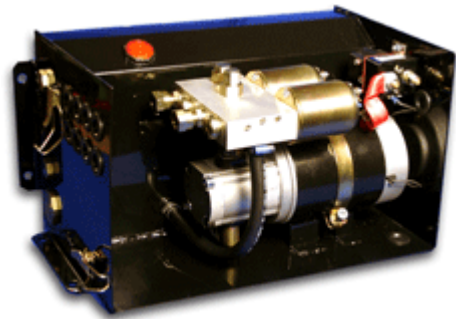

Dc compact power packs



Dc motor-pump units

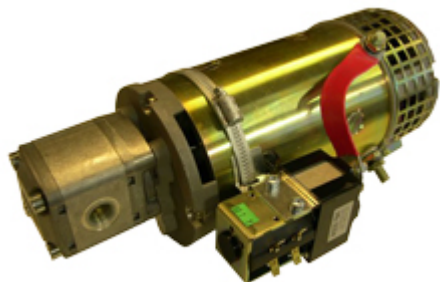



## Impress

General:

This catalogue has been written with greatest concerns. Still it can contain errors and mistakes. For errors and mistakes the author can nor be made legally liable.

Layout and content:      Hydraulfunktion GmbH

Version:                      09.0601

Publishing date:            01. June 2009

**HF**  
*power packs*

For mobile hydraulics

## Contact

### **Hydraulfunktion AB Production / Supplier**

Kungsgatan 67  
(S) 341 32 Ljungby  
Sweden

Tel: +46 (0)372 - 15840

Fax: +46 (0)372 - 15843

Email: [hf@hydraulfunktion.se](mailto:hf@hydraulfunktion.se)